

**BUILDING CONTROL ACT
(CHAPTER 256)**

BUILDING CONTROL REGULATIONS

S 70/2014

Amended by

S 57/2018

S 11/2021

REVISED EDITION 2023

SUBSIDIARY LEGISLATION

BUILDING CONTROL REGULATIONS

ARRANGEMENT OF REGULATIONS

Regulation

PART 1

PRELIMINARY

1. Citation
2. Interpretation
3. Underground building works
4. Application
5. Insignificant building works

PART 2

SUBMISSION AND APPROVAL OF PLANS

6. Application for approval of plans of building works
7. Plans of alterations and additions to buildings
8. Preparation of plans for approval
9. Scale of plans
10. Particulars to be shown on building plans
11. Particulars to be shown on detailed structural plans and design calculations
12. Particulars to be shown on site formation plans and pile layout plans
13. Particulars to be shown in underground building works plans
14. Minor building works
15. Non-acceptance of application for approval of plans
16. Approval of plans

[Subsidiary]

17. Disapproval of plans
18. Return of disapproved or withdrawn plans
19. No refund of fees
20. Amendment and record plans of building works
21. Validity period of approval
22. Application for modification or waiver of building regulations
23. Permit to carry out building works

PART 3

DUTIES OF QUALIFIED PERSONS, SITE SUPERVISORS AND BUILDERS
DURING CONSTRUCTION

24. Site records
25. Submission of progress reports and certificates
26. Large and small-scale building works
27. Site supervisors
28. Duties of qualified persons regarding underground building works
29. Change of builder

PART 4

DESIGN AND CONSTRUCTION

30. Compliance with design and construction requirements
31. Acceptable solutions
32. Lifts
33. Protective hoardings
34. Site investigation
35. Pre-construction survey
36. Impact assessment report
37. Measures to protect trenches and pits

38. Formation of new slope or embankment
39. Drainage of excavations
40. Protection of foundations and excavations
41. Instrumentation and monitoring results
42. Materials for construction
- 42A. Ready-mixed concrete
43. Construction tests
44. Failure of test
45. Taking of samples for analysis

PART 5

INSTALLATION OF EXTERIOR FEATURES

46. Interpretation
47. Installation of air-conditioning unit by trained air-conditioning unit installer
48. Duties of trained air-conditioning unit installer
49. Installation of window by trained window installer
50. Duties of approved window contractor and trained window installer
51. Qualifications for certification as trained air-conditioning unit installer
52. Requirements for registration as approved window contractor
53. Qualifications for certification as trained window installer
54. Revocation of registration

PART 6

OCCUPATION OF BUILDINGS

55. Occupation permit
56. Temporary occupation permit
57. Separation of part of building under construction

[Subsidiary]

PART 7

GENERAL

- 58. Overloading
- 59. Notice as to loads
- 60. Power to prescribe procedures and set standards
- 61. Application of standards or code of practice
- 62. Inspection and copying of approved drawings
- 63. Penalty

SCHEDULE 1 — INSIGNIFICANT BUILDING WORKS

SCHEDULE 2 — FEES FOR APPROVAL OF PLANS OF BUILDING WORKS UNDER SECTION 5

SCHEDULE 3 — SCOPE OF PROFESSIONAL PRACTICE

SCHEDULE 4 — MINOR BUILDING WORKS NOT REQUIRING CERTIFICATE OF ACCREDITED CHECKER

SCHEDULE 5 — OBJECTIVES AND PERFORMANCE REQUIREMENTS FOR DESIGN AND CONSTRUCTION OF BUILDINGS

SCHEDULE 6 — PROHIBITED CONSTRUCTION MATERIALS

SCHEDULE 7 — STRUCTURAL SUPPORTING SYSTEM FOR AIR-CONDITIONING UNIT

SCHEDULE 8 — TASKS

SUBSIDIARY LEGISLATION

Regulations made under section 74

BUILDING CONTROL REGULATIONS

Commencement: 1st November 2015
[S 5/2016]

PART 1

PRELIMINARY

Citation

1. These Regulations may be cited as the Building Control Regulations.

Interpretation

2. In these Regulations, unless the context otherwise requires —

“acceptable solution” means the specifications, design, material or method of construction set out in an Approved Document as provided in regulation 31(1);

“alternative solution” means a solution that entails the use of any design, material or method of construction that differs completely or partially from those in the acceptable solution;

“approved” means approved by the Authority;

“Approved Document” means an Approved Document issued by the Authority under regulation 31;

“building envelope” means the elements of a building which enclose air-conditioned spaces through which thermal energy may be transferred from the exterior;

“code of practice” means the relevant code of practice issued by the Authority, and where there is no such code of practice means the relevant British Standard Code of Practice or any other relevant code of practice which is acceptable to the Authority;

“existing building” means any building in respect of which an occupation permit or a temporary occupation permit has been issued;

[Subsidiary]

“floor” includes a horizontal platform forming the surface of a storey and any joist, board, timber, stone, concrete, steel or other material connected with or forming part of such platform;

“foundation” means that part of a construction immediately below the footings of a building which is in direct contact with, and through which the weight of a building is transmitted to, the ground, and includes piling works;

“fresh air” means normal outdoor air not unduly affected by odours, smoke, effluents, dust, fumes discharges from mechanical plants and the like;

“geotechnical report” means calculations, plans or report prepared in respect of underground building works by a qualified person who is a geotechnical engineer showing —

(a) the results of the findings, evaluation and interpretation of the site investigation and laboratory tests;

(b) assessment of and recommendations on the geotechnical aspects for the design and construction of the underground building works; and

(c) plans showing those elements of building works designed by the person who is a geotechnical engineer;

“immaterial changes”, in relation to building works, means any changes that —

(a) do not affect any key structural elements; or

(b) affect the key structural elements but the effects are localised in nature and do not require a re-design of the key structural elements;

“imposed load” or “imposed loading” means the load assumed to be introduced by the intended occupancy or use, including distributed, concentrated, impact and inertia but does not include wind loads;

“lift” means a lift machine or an appliance equipped with a car, platform or other device that moves along guides in a substantially vertical direction and is used for carrying persons or goods but does not include any temporary hoist in any construction site or dumb waiter or lift for the carriage of goods only;

“load bearing”, in relation to a part of a building (including its foundation), means that part of the building which bears a load other than that due to its own weight and wind pressure on its own surface;

“material changes”, in relation to building works, means any changes that affect the key structural elements of the structure to such an extent as to require a re-design of the key structural elements;

“mechanical ventilation” means the process of supplying or removing air to or from a building or part thereof by mechanical means or devices;

“natural ventilation” means the supply of outside air to a building or removal of inside air from a building by means of windows and other openings;

“record plan” means a plan showing the immaterial changes made to the building works of the approved plan;

“residential building” means a building or part thereof designed or adapted or used for human habitation such as a detached, semi-detached or terraced house or residential flat, and includes any outbuilding and other covered structure which are intended for the enjoyment of the occupiers of the building or part thereof or are otherwise appurtenant to such a building;

“retaining wall” means a structure used to resist the lateral displacement or support the load of any retained material and includes any contiguous or secant bored-piled or diaphragm wall, reinforced concrete wall, steel sheet pile wall, soil nailed wall, reinforced earth wall, crib wall, gabions wall, cofferdam, tied-back wall or other types of wall serving the same purpose;

“site formation works” means any kind of site formation and includes earthworks for site stabilisation, the construction of foundations, basements, sub-structures, piling, underpinning, ground anchors, trenches or any other kind of ground works;

“structural elements” means those parts or elements of a building which resist forces and moments and includes foundations, beams, columns, shear cores, slabs, roof trusses, staircases, load bearing walls and all other elements designed to resist forces and moments but exclude doors, windows and non-load bearing walls;

“supervising qualified person” means the qualified person appointed under section 12(1)(b) to supervise the carrying out of any building works.

Underground building works

3. For the purposes of paragraph (c) in the definition of “underground building works” in section 2, all types of foundation works for buildings of thirty or more storeys are prescribed as underground building works.

Application

4. These Regulations apply only to building works where an application to the Authority for approval of the plans of those building works under section 5(1) is made on or after the commencement of the Act.

Insignificant building works

5. For the purposes of section 4(d), insignificant building works are any of the building works set out in Schedule 1, and these Regulations do not apply to any of these insignificant building works.

[Subsidiary]

PART 2

SUBMISSION AND APPROVAL OF PLANS

Application for approval of plans of building works

6. (1) For the purposes of section 5(1), an application for approval of the plans of building works shall be accompanied by the following documents —

(a) the following plans of the building works prepared in accordance with these Regulations and such other requirements as the Authority may specify —

- (i) building plans;
- (ii) detailed structural plans and design calculations;
- (iii) site formation plans and pile layout plans; and
- (iv) where applicable, underground building works plans;

(b) a notification signed by the developer of those building works or by the qualified person appointed by the developer of those building works;

(c) where the written permission of the competent authority is required under any written law for the time being in force in respect of the development of land involving the proposed building works, a copy of the notice of grant of written permission issued by the competent authority together with the site plan approved by the competent authority;

(d) where an application has been made under section 9(1) for a waiver or modification of any requirement of these Regulations, a copy of the application;

(e) where alternative solutions are to be utilised in respect of the building works, a list of the alternative solutions together with the certification of a qualified person referred to in section 13(2)(b)(ii), where such certification has been obtained; and

(f) such other document as the Authority may require.

(2) The application for approval of plans and the documents referred to in sub-regulation (1)(b), (e) and (f) shall be —

(a) in such form as may be required by the Authority; and

(b) accompanied by the appropriate fee prescribed in Schedule 2.

Plans of alterations and additions to buildings

7. (1) Where any building works consist of repairs, alterations or additions to an existing building and the qualified person who prepared the building plans has reasonable grounds for suspecting that the building works may affect the structural stability or integrity of the building, the building plans referred to in regulation 6 shall bear a certification from an appropriate professional engineer that —

(a) he has inspected the building and investigated its overall structure; and

(b) in his opinion, the building is capable or incapable of resisting the forces and moments which may be increased or altered by reason of the repairs, alterations or additions.

(2) Where the qualified person who prepared the building plans referred to in sub-regulation (1) is a professional engineer in the appropriate discipline, he may provide the certification himself.

Preparation of plans for approval

8. All plans of building works accompanying any application for approval of the plans under section 5(1) shall be prepared and signed by a qualified person in accordance with the scope as prescribed in Schedule 3 and shall —

(a) be produced in a clear and intelligible manner;

(b) bear a title block in such format as the Authority may specify together with a project title on the right side of the plan;

(c) be fully annotated and suitable notations and symbols shall be used to show or distinguish the different types of materials to be used in the building works;

(d) bear a full description or generic name in any specification of materials or components given or shown on the plans;

(e) demarcate clearly the new building works from the existing building by suitable colour codings;

(f) delineate clearly the building works to be deleted, demolished or removed by the following colour codings —

(i) blue for existing;

(ii) red for new; and

(iii) yellow for demolishing;

[Subsidiary]

- (g) be numbered serially where the first plan is numbered as 1 of n and the last plan as n of n (n being the total number of pages of the relevant plans); and
- (h) comply with such other requirements as the Authority may determine.

Scale of plans

9. All plans of building works shall be drawn to the following scales where submitted in paper form —

- (a) key/location plan — 1:2500;
- (b) site plan — at least 1:500; and
- (c) others — at least 1:100.

Particulars to be shown on building plans

10. All building plans shall, where applicable, consist of or contain the following —

- (a) a site plan showing —
- (i) the location and layout of the site with boundary lines;
 - (ii) the outline of the building to be erected or building in which building works are to be carried out marked in colour or otherwise;
 - (iii) the north point and the number of the lot and adjoining lots;
 - (iv) the distance between the new building to be erected or the building works to be carried out and the lot boundary;
 - (v) the retaining wall on the lot;
 - (vi) the existing and proposed platform levels and slopes; and
 - (vii) the ingress and egress to the site;
- (b) the floor plan of each storey including the roof plan of the building containing or showing —
- (i) clear statements indicating the purpose of every room or space in the building;
 - (ii) the types of materials to be used or the main elements of the buildings;

- (iii) the grid lines or dimensions between columns, corridors, staircase landing and the thickness of walls and columns;
 - (iv) the type of plant, equipment or water tank proposed to be installed and the location of the equipment and every plant room or water tank room;
 - (v) clear statements indicating every part of the building that is to be air-conditioned or mechanically ventilated;
 - (vi) the existing and proposed platform levels of the site and adjoining lots;
 - (vii) the distance between the new building and the lot boundary; and
- (c) such other details or plans as the Authority may require.

Particulars to be shown on detailed structural plans and design calculations

11. (1) Notwithstanding regulations 8 and 9, all detailed structural plans shall —
- (a) be in accordance with the Act, these Regulations and any other requirements of the Authority;
 - (b) be signed by the qualified person who prepared the detailed structural plans and design calculations, and by an accredited checker or a qualified person (being a professional engineer) unless the building works are of a type in respect of which the certificate of an accredited checker referred to in section 5(2)(d) or the letter of endorsement referred to in section 5(2)(e) is not required under regulation 14;
 - (c) bear a certificate from the qualified person who prepared and signed the structural plans on all sheets of the plans stating that he has taken into consideration the loads imposed by all the building works as shown in the building plans or any amendment thereto;
 - (d) clearly indicate on the respective area of every floor plan, the imposed load for which the floor system or part thereof has been designed;
 - (e) show the type or types of foundation to be used;
 - (f) contain the specifications of the materials to be used;
 - (g) indicate the fixing and framing details of any external cladding and safety barriers against falling from a height (if applicable).

[Subsidiary]

(2) The design calculations shall be prepared in such form and manner as the Authority may require and shall —

(a) contain a content page;

(b) bear a certificate by the qualified person who prepared the detailed structural plans and design calculations on the first and last sheets of the calculations stating that, to the best of his knowledge and belief, the design calculations have been prepared in accordance with these Regulations and that he is the person who prepared the design calculations;

(c) state on the first page of the certificate of the qualified person referred to in paragraph (b) the number of pages per book and a numbering of every page in the book;

(d) contain a Design Information Sheet giving a summary of the design information including, where applicable, the design loads, codes of practice, assumptions, soil investigation report, foundation system, wind loads and other information relevant to the design in question;

(e) contain a Structural Summary Sheet showing the structural system, the form of the structure, the key structural elements, the provision for overall stability and structural analysis;

(f) contain a Grouping of Structural Elements Sheet containing a list of designed structural elements that are similar; and

(g) contain an Analysis and Design of Structural Elements Sheet showing the detailed design and calculations of —

- (i) the foundation;
- (ii) the shearwall, corewall and all structural elements resisting horizontal forces;
- (iii) the column and all vertical load bearing structural elements;
- (iv) the transfer beams or plates, cantilevers, pre-stressed beams and flat slabs;
- (v) the space truss and portal frame;
- (vi) any shaft, tunnel or connections, or cavern structure;
- (vii) the retaining walls and supporting structures; and
- (viii) the overall structural system under wind loads, if applicable.

(3) Where a computer programme is used in the design calculations —

(a) the details of the programme including assumptions, limitations and the like shall be explained by the qualified person in his submission; and

(b) the inputs and outputs from the programme shall be endorsed and submitted by the qualified person and shall form part of the design calculations submitted by him.

(4) The certificates referred to in sub-regulations (1)(c) and (2)(b) shall be in such form as the Authority may specify.

Particulars to be shown on site formation plans and pile layout plans

12. (1) Notwithstanding regulations 8 and 9, all site formation plans and calculations shall —

(a) be in accordance with the Act and these Regulations and any other requirements of the Authority;

(b) show the contour lines at intervals of 500 millimetres in height or the spot levels of the existing site and adjoining lands drawn with reference to the *ordnance datum*;

(c) show the location of the site formation works;

(d) show the finished formation levels, including platform level for the building or buildings and the finished road levels;

(e) show the slope of any excavation or filling; and

(f) show the means of protecting the site formation works against erosion, earthslip, slope failure or instability.

(2) The pile layout plans shall show —

(a) the types of piles and the specification of materials to be used;

(b) the site investigation boreholes;

(c) the estimated pile penetration depth for each design zone;

(d) the minimum embedded pile length into competent *stratum*, where applicable;

[Subsidiary]

- (e) the unit skin friction and unit end bearing resistance for pile designs, if any;
- (f) the allowable pile bearing capacity before and after deduction of negative skin friction (if applicable) and details of pile joints;
- (g) the allowable total and differential foundation settlement if any;
- (h) the allowable vibration limit during pile installation; and
- (i) the sectional details of piles and number and type of pile load tests and the location of ultimate pile load tests.

Particulars to be shown in underground building works plans

13. (1) The underground building works plans referred to in regulation 6(1)(a)(iv) shall consist of or contain the following, where applicable —

- (a) plans of any tunnelling support system;
- (b) plans of any excavation and earth retaining structures;
- (c) plans of the foundation;
- (d) instrumentation and monitoring plans.

(2) Notwithstanding regulations 8, 9 and 10, all underground building works plans shall —

- (a) be in accordance with the Act and these Regulations and any other requirements of the Authority;
- (b) be signed and endorsed by the qualified person who prepared the plans and calculations, and by the accredited checker;
- (c) bear a certificate by the qualified person who prepared the plans on the first and last sheets of the calculations stating that, to the best of his knowledge and belief, the design calculations have been prepared in accordance with these Regulations and that he is the person who prepared the design calculations;
- (d) state on the first page of the certificate of the qualified person referred to in paragraph (c) the number of pages per book and a numbering of every page in the book;
- (e) be accompanied by an Information Sheet giving a summary of the key design and construction information including, where applicable, load

conditions, codes of practice, assumptions, earth-retaining system, tunnel support system, foundation system, and other information relevant to the design and construction in question;

(f) be accompanied by an impact assessment report on neighbouring structures and a site investigation report, if any;

(g) be accompanied by a geotechnical report which shall contain —

- (i) a summary to highlight the key elements of the design and the issues addressed;
- (ii) evaluation and interpretation of existing information and investigation and monitoring results;
- (iii) assessment of geotechnical parameters and groundwater conditions;
- (iv) geotechnical assumptions, analysis, design and calculations;
- (v) geotechnical requirements relating to the design and construction of the underground building works including testing, validating, controlling, inspecting and monitoring;
- (vi) geotechnical reviews; and
- (vii) any other details as the Authority may require; and

(h) be accompanied by such other reports as the Authority may require.

(3) The plans of a tunnel support system for the design and construction of any tunnel with diameter, width or height of more than 2 metres shall contain, where applicable —

(a) layout, sections and details of all excavation and tunnel support works showing —

- (i) subsurface information including plan showing layout of investigation boreholes and subsurface profile along each tunnel axis;
- (ii) maximum depth, and extent of excavation at each stage including heading, bench and invert;
- (iii) face pressure and other key performance indicators for ensuring stability of tunnel during construction;

[Subsidiary]

- (iv) location of planned stoppages and necessary ground improvement and monitoring details; and
- (v) profile and the nature of the site and its surrounds including ground topography, neighbouring structures, subsurface geological and geotechnical data, and groundwater conditions;

(b) layout, sections, details and material specifications of tunnel support elements and structures, tunnel face support system and overall tunnel support system and other structural elements showing types, sizes and material specifications of members to be used and the connection details;

(c) layout, sections and details of earth or ground strengthening, improvement or protection works including layout, sections and sizes of all elements, material specifications, details of inspections and tests to be carried out;

(d) method and sequence of construction including duration and spatial limits of critical activities;

(e) details of inspections and tests to be carried out;

(f) details of any special precautions, groundwater control measures, control and protective measures required during excavation, installation and removal of any tunnel support element;

(g) other specifications and relevant particulars; and

(h) such other details as the Authority may require.

(4) The excavation and earth retaining system plans for any excavation or any building works for constructing, altering or repairing any earth retaining structure (including slope) in or for a caisson, cofferdam, trench, ditch, shaft or well for supporting earth which has a depth of more than 6 metres shall contain, where applicable —

(a) layout, sections and details of all excavation and earth retaining works showing —

- (i) subsurface information including plan showing layout of investigation boreholes and surface profile along and across the excavation boundary;
- (ii) maximum depth, and extent of excavation at each stage; and

(iii) profile and the nature of the site and its surrounds including ground topography, neighbouring structures, subsurface geological and geotechnical data, and groundwater conditions;

(b) layout, sections, details and material specifications of earth retaining elements and structures, wall elevation showing the wall founding depth or penetration depth or minimum wall embedment requirement, and overall retaining system;

(c) layout, sections and details of struts, anchors, soil nails, walers, king posts, bracings, corbels and other structural elements showing types, sizes and material specifications of members to be used, connection details, and where appropriate, inspections and tests to be carried out;

(d) layout and sections of earth berms or slope showing type of soils, size and location of berms, internal and external drainage provisions and protection measures including against surface weathering;

(e) layout, sections and details of earth or ground strengthening, improvement or protection works including layout, sections and sizes of all elements, material specifications, details of inspections and tests to be carried out;

(f) layout, sections and details of permanent support system to the earth retaining system showing details of lateral bracing element, and connection details;

(g) method and sequence of construction including duration and spatial limits of critical activities;

(h) details of inspections and tests to be carried out;

(i) details of any special precautions, groundwater control measures, control and protective measures required during excavation, and installation and removal of any earth retaining element;

(j) other specifications and relevant particulars; and

(k) such other details as the Authority may require.

(5) The foundation plans for the design and construction of foundation for buildings of thirty or more storeys shall contain, where applicable —

[Subsidiary]

- (a) the layout, sections and details of all foundation works showing —
- (i) types of piles or foundation and specification of material to be used;
 - (ii) location of piles or foundation and site investigation boreholes;
 - (iii) pile or foundation founding depth or pile minimum embedment into competent stratum for each pile or foundation;
 - (iv) unit shaft friction, pile base resistance or foundation bearing pressure;
 - (v) allowable foundation capacity before and after accounting for negative skin friction where applicable, allowable tension and lateral load;
 - (vi) details of pile reinforcements, pile joints, connection with pilecap, pile shops;
 - (vii) allowable total and differential foundation movement; and
 - (viii) allowable vibration limit; and

(b) the number, type of pile or foundation tests, structural integrity tests and location of preliminary test pile or ultimate load tests and site investigation for the tests.

(6) The instrumentation and monitoring plans shall contain, where applicable —

(a) layout and location of neighbouring structures in relation to the underground building works;

(b) numbers, types, locations, details and other particulars of instruments for monitoring forces and movement of structural elements, building and ground movements, and variations in the groundwater or piezometric levels;

(c) frequency and duration of monitoring;

(d) allowable ground or building movement limits;

(e) allowable vibration limits;

(f) where applicable, long-term instrumentation, monitoring and maintenance requirements;

(g) other specifications and relevant particulars; and

(h) such other details as the Authority may require.

Minor building works

14. The building works set out in Schedule 4 are building works the plans of which do not require a certification from an accredited checker for the purposes of section 5 or 6.

Non-acceptance of application for approval of plans

15. The Authority may refuse to accept an application for approval of any plans of building works if —

(a) the application or the plans of building works submitted do not comply with any requirement of the Act or these Regulations;

(b) the application is not complete or not in accordance with any other requirement of the Authority; or

(c) the fee prescribed in Schedule 2 has not been paid.

Approval of plans

16. (1) Where the Authority approves any plans of building works under section 5(3)(a), the Authority shall notify the developer of the building works and the qualified person who prepared and submitted those plans of its approval and of the conditions, if any, subject to which the approval has been granted.

(2) For the avoidance of doubt, no approval of any plans of building works under section 5(3)(a) shall be taken to —

(a) confer any title to land;

(b) act as a waiver of any condition in any lease or licence;

(c) grant any exemption from or permit any contravention of any provision of these Regulations; or

(d) waive or modify the application of these Regulations to those building works where no such waiver or modification has been granted under section 9(1) in relation to the building works.

Disapproval of plans

17. Where the Authority disapproves any plans of building works under section 5(3)(c), the Authority shall notify the developer of the building works and the qualified person who prepared and submitted those plans.

[Subsidiary]

Return of disapproved or withdrawn plans

18. (1) Where any plans of building works have been disapproved, the Authority may return the disapproved plans to the qualified person.

(2) Where any plans have been withdrawn by the qualified person or developer before or after approval, the Authority may return the plans to the qualified person or developer, as the case may be.

(3) Where the Authority has notified a qualified person or developer to collect any plans (whether on paper or in electronic form) that are to be returned under sub-regulation (1) or (2), and such plans are not collected within one month from the date of the notice, the Authority may destroy or dispose of the plans (including the medium in which they are stored) in any way the Authority thinks fit.

No refund of fees

19. The fees paid to the Authority under these Regulations shall not be refunded if the application is withdrawn at any time or disapproved or deemed to be disapproved under section 5(4).

Amendment and record plans of building works

20. (1) Where it is necessary that any building works depart or deviate from the approved plans of those building works, an application shall be made to the Authority under section 6(1) and shall, notwithstanding that section, be accompanied by the amended plan of the buildings works showing clearly the departures or deviations.

(2) Where the departures or deviations involve material changes to the structural design, the qualified person appointed under section 12(1)(a) and, in the case of major building works, the accredited checker shall submit the structural plans and design calculations to the Authority for approval before construction.

(3) Notwithstanding sub-regulation (1), where the departures or deviations involve immaterial changes, the qualified person appointed under section 12(1)(a) shall only be required to prepare and submit to the Authority —

(a) the record plans;

(b) his certificate stating that to the best of his knowledge and belief the departures or deviations do not affect the structural adequacy or stability of the building;

(c) a certificate from an accredited checker or qualified person (being a professional engineer) as the case may be, stating that to the best of his knowledge and belief, the record plans do not show any inadequacy in key

structural elements of the building to be erected or affected by building works carried out in accordance with those plans; and

(d) on the completion of the building works, a report stating the departures or deviations accompanied by the detailed structural plans and design calculations showing such departures or deviations.

(4) The qualified person appointed under section 12(1)(a) shall keep and maintain a record of all departures or deviations relating to the structural elements of the building works.

(5) The certificates referred to in sub-regulation (3)(b) and (c) shall be in such form as the Authority may specify.

Validity period of approval

21. (1) For the purposes of section 7(1)(c), the approval of any plans of building works granted by the Authority shall lapse if the building works are not commenced within one year from the date of approval.

(2) (a) A renewal of lapsed approval is allowed and is not considered as new application.

(b) Such renewal is subject to the fee as prescribed in Schedule 2.

Application for modification or waiver of building regulations

22. (1) Where any proposed building works shown in any plans do not comply with these Regulations relating to the design and construction of buildings, an appropriate qualified person appointed by the developer shall make an application under section 9(1).

(2) For the purposes of section 9(2), any such application shall be accompanied by a declaration signed by a qualified person stating every item of the building works shown in the plans that does not comply with these Regulations relating to the design and construction.

(3) Every application under section 9(1) shall be accompanied by the fee prescribed in Schedule 2.

Permit to carry out building works

23. (1) An application for a permit to carry out any building works (including structural, piling or site formation works or the demolition of a building) under section 8(1) shall be in such form as the Authority may require.

[Subsidiary]

(2) Where any part of a building under construction or undergoing alteration is to be demolished, no separate permit for the demolition works shall be required.

(3) For the purposes of section 8(2)(e), an application for a permit to carry out any demolition of a building shall be accompanied by —

(a) a method statement detailing how the demolition works are to be carried out; and

(b) an impact assessment report on surrounding buildings and other structures.

(4) For the purposes of section 8(2)(e), an application for a permit to carry out any piling or site formation works shall be accompanied by —

(a) an impact assessment report on surrounding buildings and other structures; and

(b) a notification specifying the date of commencement of the piling or site formation works.

PART 3

DUTIES OF QUALIFIED PERSONS, SITE SUPERVISORS AND BUILDERS DURING CONSTRUCTION

Site records

24. For the purposes of section 13(4)(d), the supervising qualified person appointed in respect of any building works shall keep and maintain at the premises on which the building works are carried out the following documents, books and records —

(a) for major building works, a schedule of the structural works to be carried out every 3 months, specifying, in particular, the excavation, installation, testing, removal, construction or fabrication of the key structural elements in the structural works;

(b) a record of attendance of the qualified person and the site supervisor;

(c) a site record book;

(d) a copy of the approved structural plans including all amendments;

(e) a record of all the departures or deviations relating to the structural elements of the building works as provided by the qualified person appointed under section 12(1)(a);

(f) a record of inspection and approval for concreting;

(g) a record of repairs to defective structural works;

(h) a site investigation report;

(i) a record of piles installed;

(j) record of pile load tests;

(k) record of tests on cement, sand and aggregate;

(l) a record of concrete cube tests;

(m) a record of tests on steel reinforcements;

(n) a record of tests on pre-stressing steel;

(o) a record of pre-stressing works;

(p) a record of tests on welding works and all welders' certificates;

(q) a record of ground anchor, soil nails or rock bolt tests and, where applicable, stressing loads;

(r) a record of inspection and approval at each of the following stages of the building works: excavation, installation, construction and removal stage of the building works;

(s) a record of inspection and approval for strut, soil nails, rock bolts, or anchor during installation and removal;

(t) a record of instrumentation and monitoring reports;

(u) a record of actions taken where monitoring results of earth-retaining wall deflection or adjacent ground settlements exceed the allowable limits or where damages occur in the neighbouring properties;

(v) a record and test results of earth or ground improvement or strengthening works;

[Subsidiary]

- (w) a record of tests on fixings of external claddings and safety barriers against falling from a height;
- (x) the mill certificates and test results for structural steel sections; and
- (y) a record of all other tests of or in connection with the building works.

Submission of progress reports and certificates

25. (1) For the purposes of section 13(4)(e), the supervising qualified person appointed in respect of any building works shall prepare and submit the following reports and certificates relating to the building works at the corresponding times or intervals of the building works, where applicable —

(a) *(deleted by S 57/2018)*;

(b) on completion of building works, a certificate stating that the building works and piling works have been carried out under his supervision; and
[S 57/2018]

(c) within 14 days of his ceasing to carry out his duties under the Act, a summary report of all those building works which have been carried out under his supervision and a certificate of such supervision.

(2) The certificates referred to in sub-regulation (1) shall be in such form as the Authority may require.

Large and small-scale building works

26. (1) Notwithstanding sub-regulation (3), all building works which is less than 3,000 square feet gross floor area or the value of which is less than \$250,000, where applicable, shall be exempted from section 10(1)(a).

(2) Any building works which is more than 10,000 square feet gross floor area or the value of which is more than \$1,000,000, where applicable, are large building works for the purposes of section 10(1)(b).

(3) Any building works which is less than 10,000 square feet gross floor area or the value of which is less than \$1,000,000, where applicable, are small-scale building works for the purposes of section 10(1)(c).

Site supervisors

27. (1) For the purposes of section 14(1)(a), the team of site supervisors appointed in respect of the structural elements of any large building works shall comprise —

(a) where the value of the large building works is more than \$1,000,000 but not exceeding \$5,000,000, one site supervisor who is a resident technical officer;

(b) where the value of the large building works is more than \$5,000,000 but not exceeding \$20,000,000, two site supervisors, one of whom shall be a resident technical officer and the other shall be a resident engineer;

(c) where the value of the large building works is more than \$20,000,000 but not exceeding \$50,000,000, three site supervisors, one of whom must be a resident engineer and the other two shall each be a resident technical officer;

(d) where the value of the large building works is more than \$50,000,000, four site supervisors, one of whom shall be a resident engineer and the other three shall each be a resident technical officer.

(2) For the purposes of section 14(3)(a), no person shall be appointed as a site supervisor in respect of any building works unless he is a resident technical officer or resident engineer.

(3) For the purposes of section 14(3)(b), the Authority or a prescribed organisation is the organisation to which a person is and remains accredited with in order to be appointed as a site supervisor in respect of any building works.

(4) In this regulation —

“resident engineer” means any person who —

(a) is a professional engineer in the civil or structural engineering discipline registered under the Architects, Professional Engineers and Quantity Surveyors Order, 2011 (S 33/2011);

(b) possesses a university degree or any other professional qualification recognised by the Architects, Professional Engineers and Quantity Surveyors Board for registration as a professional engineer under the Architects, Professional Engineers and Quantity Surveyors Order, 2011 (S 33/2011) in the civil or structural engineering discipline;

(c) possesses a postgraduate master’s degree or doctoral degree in Civil Engineering or Structural Engineering from any university recognised by the Architects, Professional Engineers and Quantity Surveyors Board for registration as a professional engineer under the

[Subsidiary]

Architects, Professional Engineers and Quantity Surveyors Order, 2011 (S 33/2011);

(d) is a Chartered Engineer registered by the Engineering Council United Kingdom in the Civil Engineering or Structural Engineering discipline;

(e) possesses a university degree in Civil Engineering or Structural Engineering from any university that may be specified by the Authority, and has at least one year of relevant postgraduate practical experience in design or construction of structural works as may be acceptable to the Authority; or

(f) possesses such other qualification and period of practical experience as the Authority may determine, being a qualification and practical experience that is substantially equivalent to any qualification and practical experience referred to in paragraphs (a) to (e);

“resident technical officer” means any person who —

(a) possesses a degree from any local university or a diploma from any local institution in Civil Engineering or Structural Engineering;

(b) possesses a diploma in any construction-related field from any local institution and has at least one year of such relevant practical experience in full-time supervision of structural works in construction sites in Brunei Darussalam as may be acceptable to the Authority;

(c) possesses a diploma or higher certificate from any foreign institution in Civil Engineering or Structural Engineering and has at least one year of such relevant practical experience in full-time supervision of structural works in construction sites as may be acceptable to the Authority;

(d) possesses a diploma in any construction-related field from any foreign institution and has at least 4 years of such relevant practical experience in full-time supervision of structural works in construction sites in Brunei Darussalam as may be acceptable to the Authority;

(e) possesses a degree from any foreign university in Civil Engineering or Structural Engineering and has at least one year of such relevant practical experience in full-time supervision of structural works in construction sites as may be acceptable to the Authority;

(f) possesses a degree related to Civil Engineering or Structural Engineering from any foreign university and has at least one year of such relevant practical experience in full-time supervision of structural

works in construction sites in Brunei Darussalam as may be acceptable to the Authority; or

(g) possesses such other qualification and period of postgraduate practical experience in full-time supervision of structural works in construction sites as the Authority may determine, being a qualification and practical experience that is substantially equivalent to any qualification and practical experience referred to in paragraphs (a) to (f).

Duties of qualified persons regarding underground building works

28. (1) Every qualified person appointed under section 12(1)(a) to prepare the plans of geotechnical aspects of underground building works shall carry out the tasks as prescribed in Part 1 of Schedule 8.

(2) Every supervising qualified person appointed under section 12(1) in respect of the geotechnical aspects of underground building works shall carry out the tasks as prescribed in Part 2 of Schedule 8.

Change of builder

29. If any builder is unwilling or unable to carry out his duties, his notification given under section 15(3) to the Authority shall be accompanied by a summary report describing the building works completed by him and his occupation permit in such form as the Authority may require.

PART 4

DESIGN AND CONSTRUCTION

Compliance with design and construction requirements

30. Subject to the Act and regulation 31, all buildings shall be designed and all building works shall be carried out in compliance with the objectives and performance requirements as prescribed in Schedule 5 and any other requirement in these Regulations.

Acceptable solutions

31. (1) The Authority may issue, in such form as the Authority thinks fit, and amend, one or more Approved Documents setting out the specifications, materials, designs or methods of construction (in this regulation referred to as acceptable solutions) which shall, notwithstanding any alternative means of achieving compliance, be deemed to comply with the relevant objectives and performance requirements as prescribed in Schedule 5 for the design and construction of buildings or endorse, in

[Subsidiary]

whole or in part, any document for use in establishing compliance with the requirements of these Regulations.

(2) The plans of any building works that are prepared in accordance with the acceptable solutions and any building works carried out in accordance with the acceptable solutions are deemed to comply with the relevant objectives and performance requirements as prescribed in Schedule 5.

Lifts

32. (1) No person shall, without the permission of the Authority, install any lift in any building.

(2) The Authority may grant permission to a person to install a lift in a building subject to such conditions as the Authority thinks fit.

Protective hoardings

33. (1) Where —

(a) any builder appointed under section 12(1) intends to —

- (i) erect or demolish any building;
- (ii) alter or repair an outer part of any building;
- (iii) carry out any foundation works or basement excavation including any temporary retaining works; or
- (iv) carry out any site formation works; and

(b) such works are likely to cause obstruction or inconvenience to or endanger members of the public,

the builder shall, before commencing such works, erect or cause to be erected protective hoardings or other similar temporary structures of solid and robust construction to the satisfaction of the Authority in order to separate the building or the entire site where such works are intended to be carried out from a street, footway or any adjoining or adjacent property.

(2) Where the building under construction, demolition, alteration or repair is more than three storeys in height and abuts or is near a street or other buildings, the builder shall provide catch platforms, safety nettings and other measures for the safety of the public.

(3) The builder shall, at all times, maintain such protective hoardings, catch platforms or other temporary structures in a good and proper state of repair and condition and shall paint them in light colours at regular intervals.

(4) Where protective hoardings abut a road, street or access road, the builder shall provide proper footways for the use of pedestrians.

(5) If required by the Authority, the builder shall take such other steps, precautions or safety measures within such time as may be specified by, and shall do so to the satisfaction of, the Authority.

(6) On completion of the building works, the builder shall remove or cause to be removed all protective hoardings or other similar temporary structures to the satisfaction of the Authority.

Site investigation

34. (1) Where foundation, tunnels, site formation (including excavations) or related earthworks are proposed to be constructed or carried out on any premises, an investigation of the site shall be undertaken by the qualified person appointed under section 12(1)(a) in respect of the structural elements of the relevant building works in order to establish the type and character of the ground and groundwater conditions on which the foundations, tunnels, site formation (including excavations) or earthworks are to be constructed or carried out.

(2) Whenever any site investigation is to be carried out, the qualified person appointed under section 12(1)(a) shall carry out proper and adequate site investigation —

(a) in accordance with the relevant standards and codes of practice; and

(b) by conducting adequate investigation boreholes and other appropriate investigation means, in-site field tests and laboratory tests to establish the ground and groundwater conditions, their variability and the geotechnical aspects for the works to be carried out.

(3) Whenever any site investigation is to be carried out in respect of the building works, the qualified person appointed under section 12(1)(a) shall submit the site investigation reports to the Authority and in accordance with sub-regulation (4).

(4) All site investigation reports shall contain field and laboratory data, tests and results, and shall be accompanied by a certificate from an appropriate professional engineer who, having carried out, supervised or directed the site investigation, certifies that he has verified the accuracy of the information given in the site investigation report.

[Subsidiary]

Pre-construction survey

35. (1) Where any demolition of any building, or any piling or foundation works, any tunnelling works, or any site formation works (including excavation works) are to be constructed or carried out, the builder shall, before such works, carry out a pre-construction survey to establish the condition of existing buildings and structures adjacent or in otherwise close proximity to the building works.

(2) Before the building works commence, the builder shall give to each owner of every existing building and structure adjacent or in otherwise close proximity to the building works a copy of the report of a pre-construction survey carried out under sub-regulation (1) (in this regulation referred to as the pre-construction survey report) on the owner's property.

(3) The builder shall keep at the site a complete set of all the pre-construction survey reports of pre-construction surveys carried out under sub-regulation (1) by the builder.

Impact assessment report

36. The report of any investigation under regulation 34 or 35 shall contain recommendations on the measures to be taken in connection with the construction or carrying out of any demolition of a building, any piling or foundation works, any tunnelling works, or any site formation works (including excavation works) so as to prevent any settlement or other movement which may impair the stability of or cause damage to the whole or part of any premises or building adjacent or in otherwise close proximity to the building works.

Measures to protect trenches and pits

37. The builder appointed shall take measures to ensure that the trenches and pits at the site are adequately protected against erosion, failure and instability at all times.

Formation of new slope or embankment

38. Where the building works result in the formation of a new slope or embankment, the qualified person appointed under section 12(1)(a) shall determine and ascertain the integrity and stability of the new slope or embankment; and where appropriate, provide or cause to be provided a retaining wall or other earth-retaining structure, or protective measures to stabilise the new slope or embankment.

Drainage of excavations

39. (1) The builder shall provide or cause to be provided, and shall maintain, proper and adequate drainage for all excavations as long as the excavations continue.

(2) Where any lowering of the water table is envisaged, the builder shall carry out or cause to be carried out adequate provisions to ensure that the lowering of the

water table will not cause any damage to surrounding structures, roads and other properties.

Protection of foundations and excavations

40. (1) The builder shall provide or cause to be provided earth-retaining structures to protect the sides of all foundations or excavations for any building works so as to prevent any settlement or other movement which may impair the stability of or cause damage to the whole or part of any adjoining premises or building.

(2) The supervising qualified person appointed in respect of any building works shall regularly inspect the excavations and earth-retaining structures referred to in sub-regulation (1) comprised in the building works and the builder shall maintain their safe condition at all times as long as the excavations remain.

Instrumentation and monitoring results

41. (1) Where required, the supervising qualified person appointed in respect of any building works shall provide to the Authority the results of any instrumentation monitoring carried out on the site of the building works.

(2) The supervising qualified person appointed in respect of any building works shall —

(a) regularly inspect all instrumentation for monitoring, including any settlement or movement or deformation of the ground in relation to which the building works are carried out and the structure of adjacent properties and analyse the results thereof; and

(b) report periodically to the Authority the instrumentation monitoring results.

(3) When any ground movement exceeds the allowable limits, the supervising qualified person appointed in respect of any building works and the builder of those building works shall notify the Authority as soon as practicable regarding such movement.

(4) A builder of any building works shall —

(a) where applicable, provide or cause to be provided protective measures for the structures of adjacent properties so that their safe condition is maintained at all times as long as the excavations continue;

(b) put in place protective measures to prevent damage to the instrumentation for monitoring referred to in sub-regulation (2);

[Subsidiary]

(c) notify the supervising qualified person appointed in respect of the building works of any such instrumentation that is damaged or malfunctioned as soon as practicable; and

(d) replace or cause to be replaced any such instrumentation that is damaged or malfunctioning in a timely manner.

Materials for construction

42. (1) No person shall use or cause to be used in any building works any material as prescribed in Schedule 6 without the approval of the Authority.

(2) The Authority may grant approval under sub-regulation (1) subject to such conditions as the Authority thinks fit.

(3) The Authority may, at any time in writing, direct the supervising qualified person appointed in respect of any building works or the builder thereof to furnish to the Authority within 14 days from the date of receipt of such written direction —

(a) samples of the materials used in the building works;

(b) information on the source thereof;

(c) specifications of the materials; and

(d) reports of tests carried out on the materials, and the supervising qualified person or builder shall comply with such direction.

Ready-mixed concrete [S 57/2018]

42A. (1) No person shall use or cause to be used any ready-mixed concrete for structural elements in any major building works, unless —

(a) the ready-mixed concrete is obtained from a plant in respect of which valid product conformity certificate has been issued; and

(b) the specification of the ready-mixed concrete is listed in the product conformity certificate.

(2) In this regulation, “product conformity certificate” means a certificate issued by the Authority for the certification of ready-mixed concrete.

Construction tests

43. (1) The tests to be conducted of or in connection with building works under section 11(1) shall be in accordance with the objectives and performance requirements as prescribed in Schedule 5.

(2) For the purposes of section 11(2), construction tests to be carried out in respect of the materials used in the building works and the building works shall be carried out in the following manner —

(a) any test that is to be carried out at the premises where building works are carried out shall be carried out in accordance with approved standards under the direction and supervision of the supervising qualified person appointed in respect of those building works;

(b) any test that is to be carried out in a laboratory shall be carried out in an accredited laboratory approved by the Authority;

(c) the taking of any sample of subject matter for carrying out such tests shall be carried out under the supervision and direction of the supervising qualified person appointed in respect of those building works; and

(d) any test of materials used in building works shall be conducted on a sample taken from the same materials used or to be used in the building works.

Failure of test

44. (1) Where any test carried out at the premises or in any accredited laboratory fails to meet the minimum requirements stipulated in these Regulations or any approved code of practice, the supervising qualified person shall —

(a) notify the Authority as soon as practicable; and

(b) together with the qualified person appointed under section 12(1)(a) recommend appropriate steps, measures or remedial works to be carried out.

(2) Where the steps, measures or remedial works recommended under sub-regulation (1)(b) are acceptable to the Authority, the Authority may —

(a) direct the supervising qualified person to implement, or cause to be implemented, the recommendations within such period of time as may be specified by the Authority; or

(b) give any other written direction on other appropriate steps or measures to be taken,

and the supervising qualified person shall comply with such direction.

[Subsidiary]

Taking of samples for analysis

45. (1) For the purposes of section 57(3) and subject to sub-regulation (2), any sample of building materials used in any building works shall be taken in the manner —

(a) the person taking the sample (referred to in this regulation as a sampling officer) shall immediately notify the developer, the supervising qualified person appointed in respect of the building works or any other person having possession of the building materials of his intention to take the sample;

(b) the sampling officer shall, after taking the sample, immediately divide the sample into three parts and cause each part to be marked and sealed or fastened in such manner as its nature will permit in the presence of the person referred to in paragraph (a);

(c) the sampling officer shall deliver one part of the sample to the person referred to in paragraph (a); and

(d) the sampling officer shall personally deliver one part of the sample to an analyst for analysis and retain the remaining one part for future comparison.

(2) Where it is not reasonably practicable to divide any sample or the division of the sample might impede the proper analysis of the materials, sub-regulation (1) shall be taken to be complied with if the sampling officer —

(a) causes the sample to be marked and sealed or fastened in such manner as its nature will permit in the presence of the person referred to in sub-regulation (1)(a); and

(b) then personally delivers the sample to an analyst for analysis.

PART 5

INSTALLATION OF EXTERIOR FEATURES

Interpretation

46. In this Part —

“air-conditioning unit” includes a window air-conditioning unit and any condensing equipment of an air-conditioning unit;

“approved window contractor” means a company or firm which is registered by the Authority as an approved window contractor;

“installation” includes repairing, replacing, modifying and other works connected with or carried out for the purpose of installation;

“trained air-conditioning unit installer” means an individual certified by the Authority as a trained air-conditioning unit installer;

“trained window installer” means an individual certified by the Authority as a trained window installer.

Installation of air-conditioning unit by trained air-conditioning unit installer

47. (1) Any person who desires to install an air-conditioning unit, on the exterior of any building, or which projects outwards from any building, shall engage a trained air-conditioning unit installer to carry out the installation works relating to the air-conditioning unit.

(2) No person shall install any air-conditioning unit, on the exterior of any building or which projects outwards from any building, unless he is a trained air-conditioning unit installer.

(3) Any person who contravenes sub-regulation (1) or (2) is guilty of an offence and liable on conviction to a fine not exceeding \$5,000, imprisonment for a term not exceeding 6 months or both.

Duties of trained air-conditioning unit installer

48. (1) Subject to sub-regulation (2), every trained air-conditioning unit installer engaged to carry out the installation works relating to an air-conditioning unit under regulation 47 shall install a structural supporting system for the air-conditioning unit that complies with the specifications set out in Part 1, 2, 3 or 4 of Schedule 7, as the case may be, and any other requirement in these Regulations.

(2) A trained air-conditioning unit installer may depart from the specifications and requirements under sub-regulation (1) if he has obtained the prior written approval of the Authority to such departure.

[S 57/2018]

(3) A trained air-conditioning unit installer shall, not later than 14 days after the completion of installation works relating to any air-conditioning unit, submit a report of the completed works to the Authority, in such form as the Authority shall determine.

(4) Any trained air-conditioning unit installer who fails to comply with sub-regulation (1) or (3) is guilty of an offence and liable on conviction to a fine not exceeding \$5,000, imprisonment for a term not exceeding 6 months or both.

[Subsidiary]

Installation of window by trained window installer

49. (1) Any person who desires to install a window on any building shall engage an approved window contractor to install the window.

(2) Subject to sub-regulation (3), no person shall install any window that is or is to be an exterior feature of any building unless —

(a) he is a trained window installer; or

(b) he is doing so under the supervision and guidance of a trained window installer.

(3) No trained window installer shall install, or supervise and guide the installation of, any window that is or is to be an exterior feature of any building unless he is —

(a) a director;

(b) a partner;

(c) the sole proprietor; or

(d) an employee,

of an approved window contractor engaged under sub-regulation (1).

(4) Any person who contravenes sub-regulation (1), (2) or (3) is guilty of an offence and liable on conviction to a fine not exceeding \$5,000, imprisonment for a term not exceeding 6 months or both.

Duties of approved window contractor and trained window installer

50. (1) Every approved window contractor and every trained window installer appointed to install a window under regulation 49 shall carry out the works in compliance with the objectives and performance requirements as prescribed in Schedule 5 relating to the safety of windows and any other requirements in these Regulations.

(2) Any approved window contractor or trained window installer who fails to comply with sub-regulation (1) is guilty of an offence and liable on conviction to a fine not exceeding \$5,000, imprisonment for a term not exceeding 6 months or both.

Qualifications for certification as trained air-conditioning unit installer

51. No person shall be certified by the Authority as a trained air-conditioning unit installer unless he has completed such training course on the installation of a structural supporting system to support an air-conditioning unit as the Authority may require.

Requirements for registration as approved window contractor [S 57/2018]

52. The Authority may register as an approved window contractor of a company or firm which has at least two trained window installers each of whom is either a director, a partner, the sole proprietor or an employee of the company or firm, as the case may be.

Qualifications for certification as trained window installer

53. No person shall be certified by the Authority as a trained window installer unless —

(a) he has completed such training course on safety of windows as the Authority may require; and

(b) he has, before commencing the training course referred to in paragraph (a), acquired one year or such other period of practical experience in the installation of windows as the Authority may require.

Revocation of registration

54. (1) The Authority may revoke the registration of any approved window contractor which —

(a) has been convicted of an offence which, in the opinion of the Authority, renders it unfit to remain registered as an approved window contractor;

(b) has breached any of the conditions of its registration; or

(c) is, in the opinion of the Authority, unable to effectively carry out its duties under these Regulations or any other building regulations as an approved window contractor.

(2) Where the Authority intends to revoke the registration of any approved window contractor under sub-regulation (1), the Authority shall notify that approved window contractor and give it an opportunity to be heard.

(3) Any approved window contractor whose registration has been revoked under sub-regulation (1), may, within 14 days after receiving notice of such revocation, appeal to the Minister whose decision is final.

[Subsidiary]

PART 6

OCCUPATION OF BUILDINGS

Occupation permit

55. (1) On completion of any building works, the developer of the building works shall apply to the Authority for —

(a) an occupation permit; or

(b) a temporary occupation permit.

(2) The Authority may issue an occupation permit in respect of a building or any part thereof in respect of which any building works have been carried out where —

(a) the building works have been completed in accordance with the Act and these Regulations;

(b) every report and certificate referred to in regulation 25 have been submitted by the qualified person to the Authority in accordance with that regulation;

(c) the certificate from the builder referred to in section 15(1)(d) has been submitted to the Authority within 7 days of the completion of the building works;

(d) all the written directions given by the Authority to the qualified person who prepared the plans of the building works or who supervised the carrying out of the building works or part thereof under section 5(3)(b) have been complied with;

(e) all the requirements either shown or endorsed on the approved plans have been complied with;

(f) the record plans of the detailed structural plans and the design calculations incorporating all the departures or deviations from the approved structural plans and design calculations have been submitted to the Authority;

(g) the access road and infrastructure to the building or any part thereof has been completed according to the specifications set by the Authority; and

(h) such other certificate or document as may be required by the Authority has been submitted.

(3) An application for an occupation permit shall be made in such manner and be in such form as the Authority may require.

Temporary occupation permit

56. (1) An occupation permit shall not be issued in respect of any building where —

(a) there are requirements still to be complied with under the Act or these Regulations;

(b) any of the written directions or requirements shown or endorsed on the plans have not been fully complied with;

(c) there are departures or deviations from any approved plans of building works; or

(d) the building works have not been fully completed.

(2) Notwithstanding sub-regulation (1), the Authority may, if the Authority is satisfied that the non-compliance, deviation or non-completion of the building works is neither of a serious nature nor in any way detrimental to the well-being or safety of the persons who may occupy the building or part thereof, grant a temporary occupation permit for the occupation or use of the building.

(3) A temporary occupation permit may be granted where —

(a) every report or certificate referred to in regulation 25 by the qualified person has been submitted to the Authority;

(b) the certificate from the builder referred to in section 15(1)(d) has been submitted to the Authority within 7 days of the completion of the building works;

(c) the record plans of the detailed structural plans and the design calculations incorporating all the departures or deviations from the approved structural plans and design calculations have been submitted to the Authority; and

(d) such other certificate or document as may be required by the Authority has been submitted.

(4) An application for a temporary occupation permit shall be made in such form and manner as the Authority may specify.

[Subsidiary]

Separation of part of building under construction

57. Where a temporary occupation permit for part of the building is granted, the person for whom the temporary occupation permit is granted shall ensure that the part that may be occupied are separated from the other parts with proper hoardings or other barriers.

PART 7

GENERAL

Overloading

58. (1) No building shall be subjected to any load beyond its design loads as indicated in the approved detailed structural plans and design calculations relating to the building.

(2) Sub-regulation (1) does not apply with respect to any load which may be required or permitted by the Authority for the purpose of load testing.

Notice as to loads

59. In every storey of a non-residential building, there shall be exhibited by the owner of the building, at an appropriate place, permanently and conspicuously, a floor diagram and a notice incised or embossed on metal, plastic or other durable material stating the imposed load for which the floor has been designed.

Power to prescribe procedures and set standards

60. The Authority may issue or amend codes or other documents setting out such standards, designs, requirements, procedures or other details pertaining to the matters under the Act and these Regulations, not inconsistent with the Act and these Regulations, as the Authority thinks fit.

Application of standards or code of practice

61. Where any standard or code of practice is cited or referred to in any document issued under these Regulations, and there is subsequently issued a corresponding Brunei Darussalam standard on the same subject matter, the document shall be construed as if the corresponding Brunei Darussalam standard has superseded such standard or code of practice and shall be complied with.

Inspection and copying of approved drawings

62. The Authority may allow the approved drawings of building works kept in his office to be inspected and copied by the owner of the building or the owner's authorised agent on such conditions as the Authority may decide.

Penalty

63. Any qualified person, builder, site supervisor or developer of building works, as the case may be, who contravenes regulation 28, 29, 30, 32, 33, 34, 35, 36, 37, 38, 39, 40, 41, 42, 42A, 44, 57, 58(1) or 59 is guilty of an offence and liable on conviction to a fine not exceeding \$10,000, imprisonment for a term not exceeding one year or both.

[S 11/2021]

SCHEDULE 1

(regulation 5)

INSIGNIFICANT BUILDING WORKS

1. Building works carried out for or in connection with —

- (a) any single storey trellis, pergola, shelter, gazebo and the like;
- (b) any pipe rack or support not exceeding 2,000 millimetres in height;
- (c) any height restriction gantry;
- (d) any plinth, platform or other base with a visible height not exceeding 1,000 millimetres from the ground level and erected for the purpose of supporting any mechanical plant, tank, equipment, machinery or other components (other than a building);
- (e) the creation of any opening in a non-load bearing wall or the sealing up of any wall opening;
- (f) the demolition, restoration or reinstatement of any non-load bearing wall;
[S 57/2018]
- (g) any shaft, manhole, trench or tunnel for the purpose of laying sewer, water or other utility pipes, where —
 - (i) the pipe does not exceed 1,000 millimetres in internal diameter; and
 - (ii) the building works are not located within the site of other building works that are not specified in this Schedule;
[S 57/2018]
- (h) any canal or drain not exceeding 1,500 millimetres in depth;
[S 57/2018]
- (i) any box culvert with a span not exceeding 5,000 millimetres and a depth not exceeding 1,500 millimetres;
[S 57/2018]
- (j) any boundary wall, boundary fence or gate;
[S 57/2018]

SCHEDULE 1 — (continued)

(k) any awning, windowhood or cantilevered roof constructed of tiles, lightweight material or glass, and having a projection not exceeding 1,200 millimetres;

[S 57/2018]

(l) any stall or shed of lightweight material within any premises;

[S 57/2018]

(m) the enclosing of any side of a balcony, yard or terrace with windows and glass panels in residential buildings;

[S 57/2018]

(n) any single storey building used for agriculture or to house livestock, including a greenhouse or a building used to house fixed plant or machinery for the farm, provided that —

(i) no part of the building is used as a dwelling or for the purposes of packing, exhibiting or retailing; and

(ii) each point of the building is situated not less than 1.5 times its height away from any adjacent building or any route of public access;

[S 57/2018]

(o) any pre-fabricated swimming or wading pool placed on the ground, provided that —

(i) the maximum depth of water contained in the pool is not more than 1,000 millimetres; and

(ii) where the pool is located on higher ground, the distance between the pool and any retaining structure or slope is more than 3,000 millimetres and the difference in elevation of the ground levels is less than 1,500 millimetres.

[S 57/2018]

2. Replacement or changing of windows and doors.
3. Replacement of existing floor and wall finishes.
4. Replacement or changing of any false ceiling with lightweight material.

[Subsidiary]

SCHEDULE 1 — *(continued)*

5. One to one replacement of timber roof or other roof covering not involving any replacement of roof trusses.

6. Erection or alteration of —

(a) any partition or partition wall in any bungalow, semi-detached, terrace or linked house; or

(b) any partition or partition wall constructed of lightweight material in any other building.

6A. Erection at the ground level of any single storey detached booth, covered walkway, kiosk, guardhouse, bin centre, and the like, not exceeding an area of 10 square metres.

[S 57/2018]

6B. Erection of any single storey lean-to extension with roof covering of tiles, or of any lighter material, in any bungalow, semi-detached, terrace or linked house not exceeding an area of 16 square metres.

[S 57/2018]

6C. Erection of any single storey shed or hut not exceeding an area of 10 square metres for housing fuel tanks, mechanical or electrical equipment.

[S 57/2018]

7. Construction of any raised floor or the topping up of balconies, and the like, with lightweight materials.

8. Installation of any roller shutter or grilled door.

9. All air-conditioning works.

10. In this Schedule —

“lightweight material” means —

(a) any sheet or board material such as timber board, plywood, fibreboard, plasterboard, aluminium sheet, corrugated metal sheet or polycarbonated sheet;

(b) any concrete product made with lightweight aggregates such as pumice, perlite or vermiculite; or

SCHEDULE 1 — *(continued)*

(c) any hollow concrete block, hollow glass block, autoclaved aerated concrete block and the like;

“non-load bearing wall” means a wall which supports no load other than its own weight;

“partition” means a temporary or an easily removable vertical panel of lightweight construction for the subdivision of spaces within a building.

[Subsidiary]

SCHEDULE 2

(regulations 6(2), 15(c), 21 and 22(3))

FEEES FOR APPROVAL OF PLANS OF BUILDING WORKS UNDER SECTION 5

New building and extensions to buildings

1. \$3 for every 10 square metres of new building or extension or part thereof with a minimum of \$25.

[S 57/2018]

Alterations to buildings

2. \$3 for every \$2,000 of the estimated alteration cost or part thereof, with a minimum fee of \$30.

[S 57/2018]

Renewal of lapsed approval

3. \$3 per year or part thereof for renewal of lapsed approval.

[S 57/2018]

SCHEDULE 3

(regulation 8)

SCOPE OF PROFESSIONAL PRACTICE

No qualified person shall prepare or sign the plans of building works —

(a) for any of the projects listed in Part 1 unless he is a professional engineer;

(b) for any of the projects listed in Part 2 unless he is a professional engineer or an architect except that for structural components and works relating to such projects, the structural plans shall be prepared by a professional engineer; and

(c) for any other project not listed in Parts 1 and 2 unless he is an architect except that for structural components and works relating to such projects, the structural plans shall be prepared by a professional engineer.

PART 1

1. Airport runways, taxiways and aprons
2. Bridges, causeways, tunnels and underpasses
3. Bulk handling complexes
4. Chimneys
5. Claddings and curtain walls
6. Concrete tanks
7. Crane gantries
8. Culverts
9. Dry docks, jetties, quays, slipways, harbours, wharves and marine structures
10. Retaining wall and stabilising earth structures
11. Site formation works, foundations and plinths
12. Transmission towers.

[Subsidiary]

SCHEDULE 3 — *(continued)*

PART 2

1. Alterations, additions and extensions to detached, semi-detached and terraced houses
2. Alterations and additions within existing buildings which do not affect the building envelope
3. Bus depots and train depots
4. Cable car stations and towers
5. Electric substations
6. Farm structures
7. Grandstands and sports stadium
8. Helicopter ports
9. Industrial buildings
10. Marinas
11. Pedestrian overhead bridges
12. Petrol service stations
13. Power stations
14. Pumping stations
15. Satellite tracking stations
16. Shipyards
17. Silos
18. Swimming pools
19. Warehouses and godowns.

SCHEDULE 4

(regulation 14)

MINOR BUILDING WORKS NOT REQUIRING CERTIFICATE
OF ACCREDITED CHECKER

1. Building works for or in connection with —

(a) detached houses, semi-detached houses, terraced or linked houses for residential purposes not exceeding four storeys;

(b) detached substations not exceeding two storeys, detached bin centres, detached guard houses and the like; and

(c) retaining walls and earth stabilising structures not exceeding a visible height of 4 metres;

(d) shophouses not exceeding two storeys (where attic or basement floor exceeding an area of 100 square metres shall be considered as a storey);

(e) single storey buildings, sheds and the like where the span of beams or roof trusses is not more than 6 metres and the floor area is not more than 150 square metres;

(f) underground tank, swimming pool and the like not exceeding a depth of 4 metres;

(g) single storey covered walkway, car parking shed and the like where the span of the beams or roof trusses is not more than 6 metres or the span of any cantilever is not more than 3 metres;

(h) box culverts, canal crossings or link bridges with spans not exceeding 5 metres;

(i) chimneys, lighting masts and the like not exceeding 20 metres in height;

(j) foundation for above ground tank structure where the length, width or diameter of the foundation does not exceed 6 metres; and

(k) foundation for gantry cranes with capacity not exceeding 3 tonnes and the span between supports not exceeding 6 metres in any direction.

2. Structural works consisting of repairs, alterations and additions to an existing building which do not materially affect the key structural elements of the building.

SCHEDULE 5

(regulations 30, 31, 43(1) and 50)

**OBJECTIVES AND PERFORMANCE REQUIREMENTS FOR DESIGN
AND CONSTRUCTION OF BUILDINGS****A. General**

1. This Schedule prescribes the objectives and performance requirements that must be complied with in the design and construction of a building.
2. The objectives and performance requirements prescribed herein are deemed to have been satisfied if the design and construction of a building complies with the acceptable solutions prescribed in the Approved Document.

B. Structural Design and Construction – Objective

3. The objectives of paragraphs 4 to 7 are to —
 - (a) protect people from injury caused by structural failure;
 - (b) protect people from loss of amenity caused by structural failure; and
 - (c) protect other property from physical damage caused by structural failure.

Performance requirement

4. A building, including its foundation, shall be designed and constructed so that the combined dead, imposed, wind and other intended loads can be sustained and transmitted by it to the ground —
 - (a) safely; and
 - (b) without causing such deflection or deformation of any part of that building, or such movement of the ground, as will impair the stability of any part of another building or property.
5. The building shall be constructed with materials that are appropriate for the circumstances in which they are used.
6. Tests that are appropriate to the materials and building works concerned shall be performed on those materials and building works.
7. If a building or any part thereof is to be demolished, the demolition works shall be carried out safely and without impairing the stability of any other part of that building or another property.

SCHEDULE 5 — (continued)

C. Headroom and ceiling height – Objective

8. The objective of paragraph 9 is to protect people from —

- (a) injury caused by inadequate headroom; and
- (b) injury or loss of amenity caused by inadequate height of room or space.

Performance requirement

9. All rooms and spaces in a building shall be provided with adequate headroom and height for their intended uses.

10. The requirement in paragraph 9 does not apply to the following rooms and spaces —

- (a) an attic room;
- (b) equipment and plant rooms;
- (c) the underside of a staircase or escalator if such staircase or escalator is not located along an access route or circulation space;
- (d) toilets, bathrooms or lavatories; and
- (e) store rooms, utility rooms, wash area and the like.

D. Accessibility in built environment – Objective [S 57/2018]

11. The objective of paragraphs 12 to 15 is to ensure that persons with disabilities are able to easily gain access to and exit from the whole or part of a building, and that persons with disabilities, children between 90 cm and 120 cm in height, caregivers of infants, and nursing women are able to carry out their activities within the building with reasonable ease.

[S 57/2018]

Performance requirement

12. At least one access route shall have barrier-free features to enable persons with disabilities to —

- (a) approach the building or the vehicle park; and
- (b) have access to those spaces where they may be expected to work or visit.

[Subsidiary]

SCHEDULE 5 — (continued)

13. Sanitary facilities that are appropriate for use by persons with disabilities, and sanitary facilities that are appropriate for use by children between 90 cm and 120 cm in height, shall be adequately provided for use by such persons.

[S 57/2018]

14. Barrier-free facilities that are appropriate for the intended type of building or occupancy shall be adequately provided.

15. Signages shall be adequately provided to guide persons with disabilities to spaces or facilities where or which they may be expected to work, visit or use.

E. Staircases – Objective

16. The objective of paragraphs 17, 18 and 19 is to protect people from injury and to facilitate access during movement from one level to another in a building.

Performance requirement

17. A staircase (including a flight of two steps or more) shall provide a safe and suitable passage for the movement of people.

18. A staircase shall have —

(a) handrails or guides to assist movement;

(b) landings to break a fall and provide a place for rest;

(c) sufficient headroom to avoid injury; and

(d) barriers against falling from 1,000 millimetres or more from an open side.

19. Paragraphs 17 and 18 apply only to staircases that provide access to levels having rooms or spaces meant for human occupation.

F. Lighting – Objective

20. The objective of paragraphs 21 and 22 is to protect people from injury or loss of amenity due to isolation from natural lighting and lack of artificial lighting.

Performance requirement

21. Lighting shall be adequately provided in a building for its intended purpose.

SCHEDULE 5 — (continued)

22. Residential buildings, other than houses built by the owners for their own use, shall be provided with natural lighting for the purpose of paragraph 21.

G. Ventilation – Objective

23. The objective of paragraphs 24 and 25 is to protect people from loss of amenity due to lack of fresh air.

Performance requirement

24. Ventilation shall be adequately provided in a building for its intended occupancy.

25. Residential buildings, other than houses built by the owners for their own use, shall be provided with natural ventilation for the purpose of paragraph 24.

H. Safety from falling – Objective

26. The objective of paragraph 27 is to protect people from injury caused by falling.

Performance requirement

27. Where there is a vertical drop in level of 1,000 millimetres or more, appropriate measures shall be taken to prevent people from falling from a height.

28. The requirement in paragraph 27 does not apply to —

(a) roofs or other areas generally not intended for human occupation; and

(b) special service or usage areas such as loading or unloading bays, stages for performance or entertainment.

I. Energy efficiency – Objective

29. The objective of paragraphs 30 and 31 is to facilitate efficient use of energy.

Performance requirement

30. A building shall be designed and constructed with energy conservation measures to reduce —

(a) solar heat gain through the roof;

(b) solar heat gain through the building envelope;

[Subsidiary]

SCHEDULE 5 — (continued)

(c) air leakage through doors, windows and other openings on the building envelope;

(d) energy consumption of lighting, air-conditioning and mechanical ventilation systems; and

(e) energy wastage through adequate provisions of switching means.

31. Commercial buildings with an aggregate floor area of more than 500 square metres shall be installed or equipped with means to facilitate the collection of energy consumption data.

J. Roof – Objective

32. The objective of paragraph 33 is to protect the roof of semi-detached houses, terraced houses and linked houses from physical damage when repairs, alterations or additions to the roof of an adjoining house are being carried out.

Performance requirement

33. The roof shall be designed and constructed such that the roof of every house is separate and independent of each other.

K. Lifts and escalators – Objective

34. The objective of paragraphs 35 and 36 is to provide a convenient means of vertical transportation and to protect people from injury while using the lifts or escalators.

Performance requirement

35. Lifts and escalators shall —

(a) move people safely; and

(b) not produce excessive acceleration or deceleration.

36. A building comprising five or more storeys (including the ground level) shall be provided with one or more passenger lifts.

L. Lightning protection – Objective

37. The objective of paragraph 38 is to protect a building from the direct effects of lightning strike and to protect its occupants from the risk of lightning current being discharged through the building.

SCHEDULE 5 — (continued)

Performance requirement

38. A lightning protection system shall be capable of protecting the building and its occupants from the effects of lightning strike.

M. Safety of windows – Objective

39. The objective of paragraphs 40 and 41 is to protect people from injury caused by falling windows.

Performance requirement

40. A window system shall be adequately designed and constructed with appropriate materials for its intended use.

41. A casement window system shall have —

(a) fasteners, fixings, hinges and stays of adequate number, size and strength to safely support the weight of the window system and other loads imposed on it;

(b) a structural frame profile that is of adequate size and strength and adequately reinforced at locations where screws or rivets are to be affixed; and

(c) appropriate design and materials used to minimise occurrence of localised corrosion.

[Subsidiary]

SCHEDULE 6

(regulation 42)

PROHIBITED CONSTRUCTION MATERIALS

The following materials shall not be used in any building works —

- (a) high alumina cement;
- (b) aggregates which have potential for alkali-carbonate reaction or alkali-silica reaction for concrete work, including all other volcanic rocks or aggregates deriving from volcanic rocks;
- (c) admixtures containing calcium chloride;
- (d) reflective glass with a daylight reflectance exceeding 20 *per cent* on any external surface of any window, door, wall or roof of a building;
- (e) asbestos.

SCHEDULE 7

(regulation 48)

STRUCTURAL SUPPORTING SYSTEM FOR AIR-CONDITIONING UNIT

PART 1

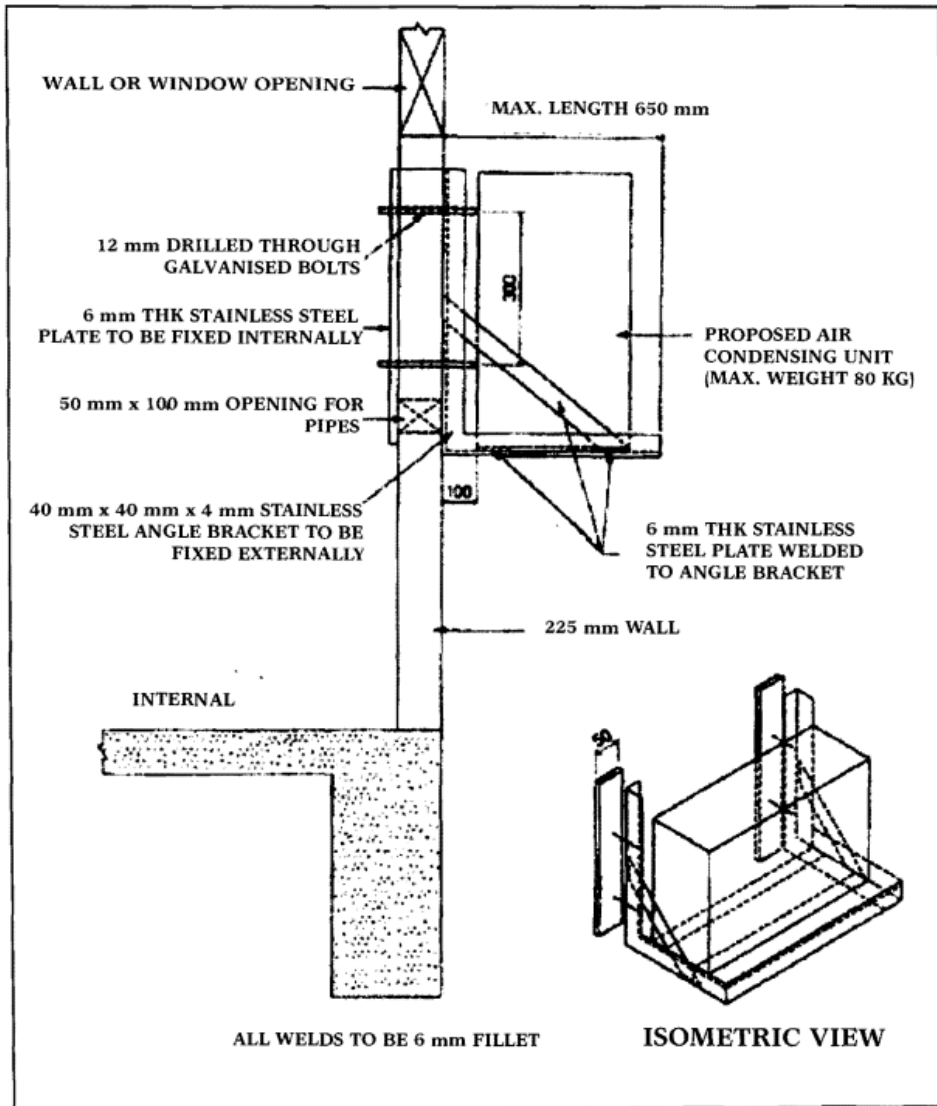

SCHEDULE 7 — (continued)

PART 2

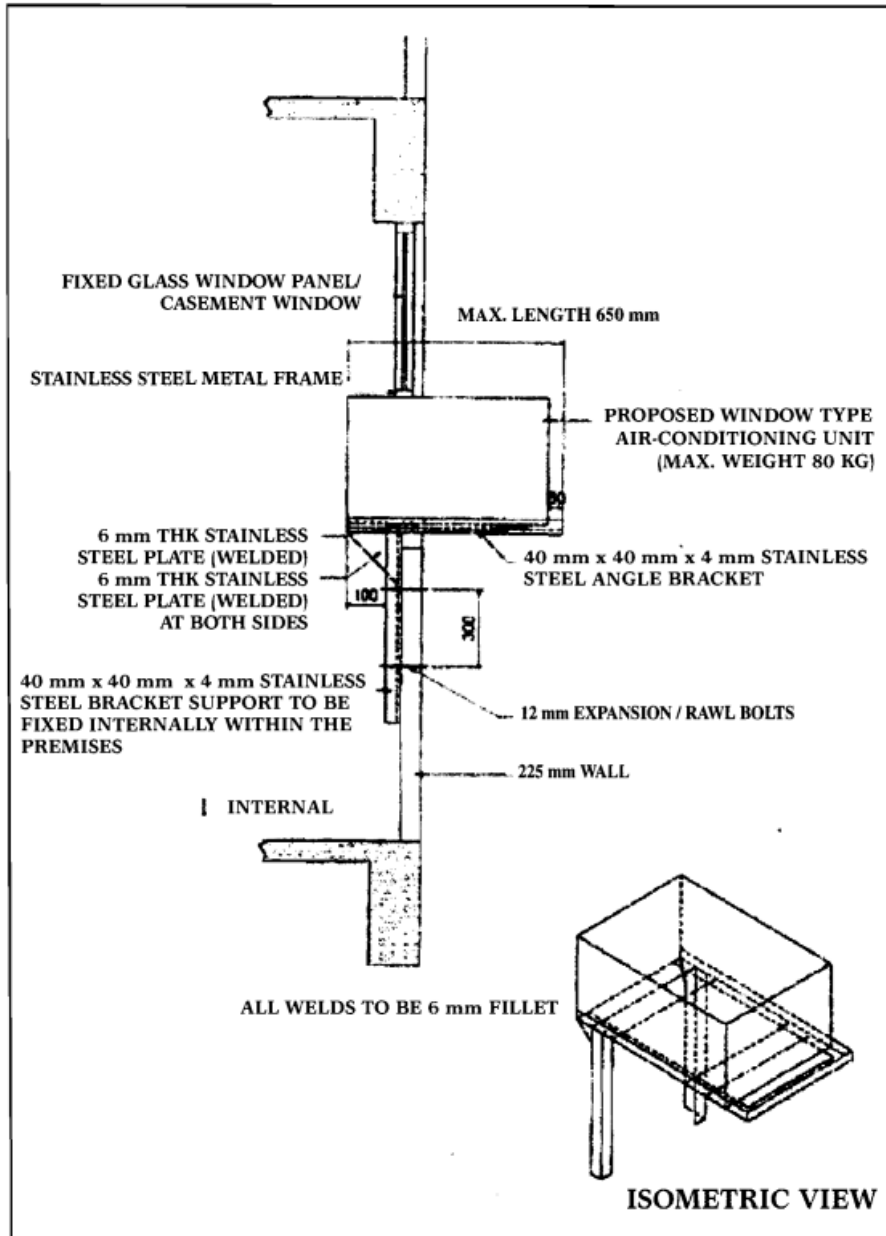

SCHEDULE 7 — (continued)

PART 3

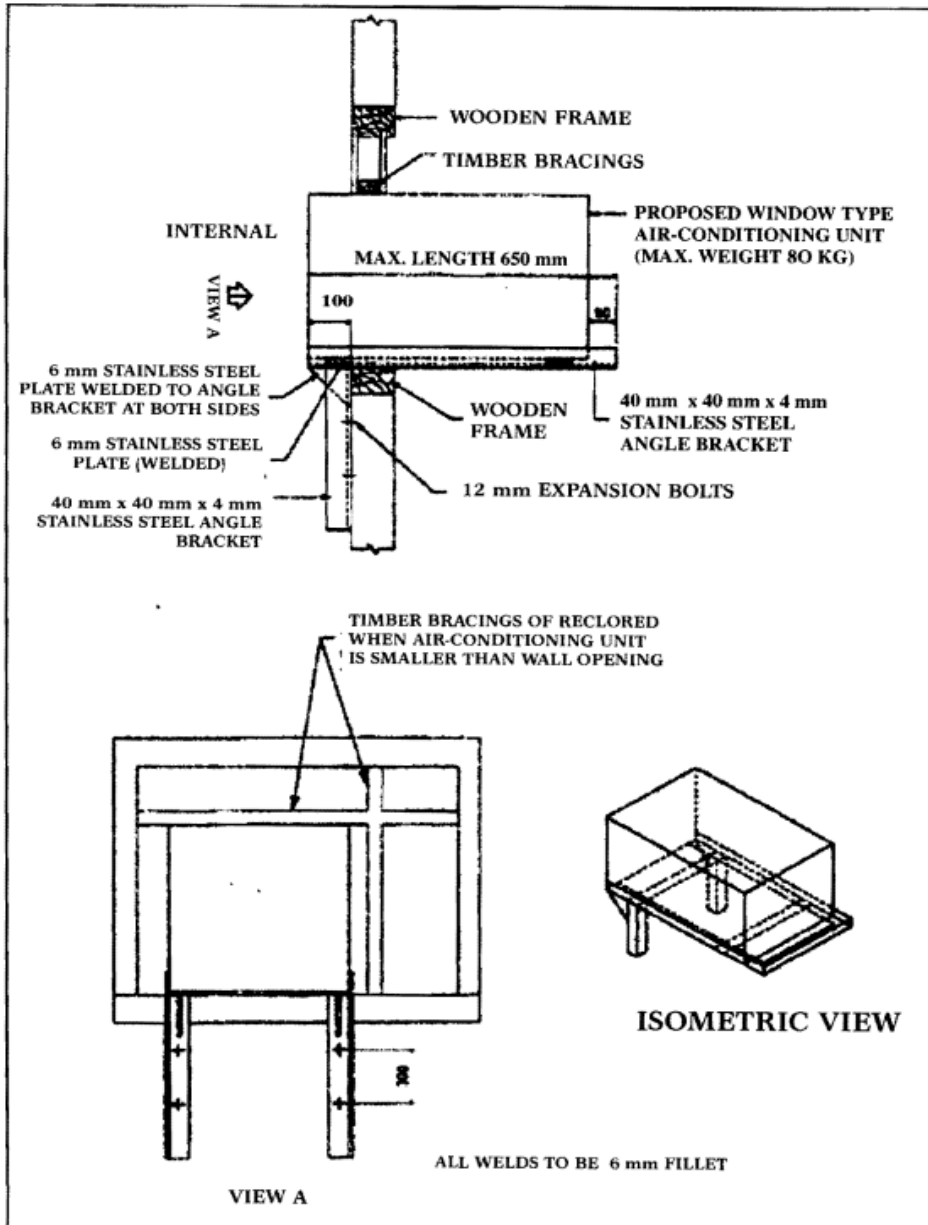

[Subsidiary]

SCHEDULE 7 — (continued)

PART 4

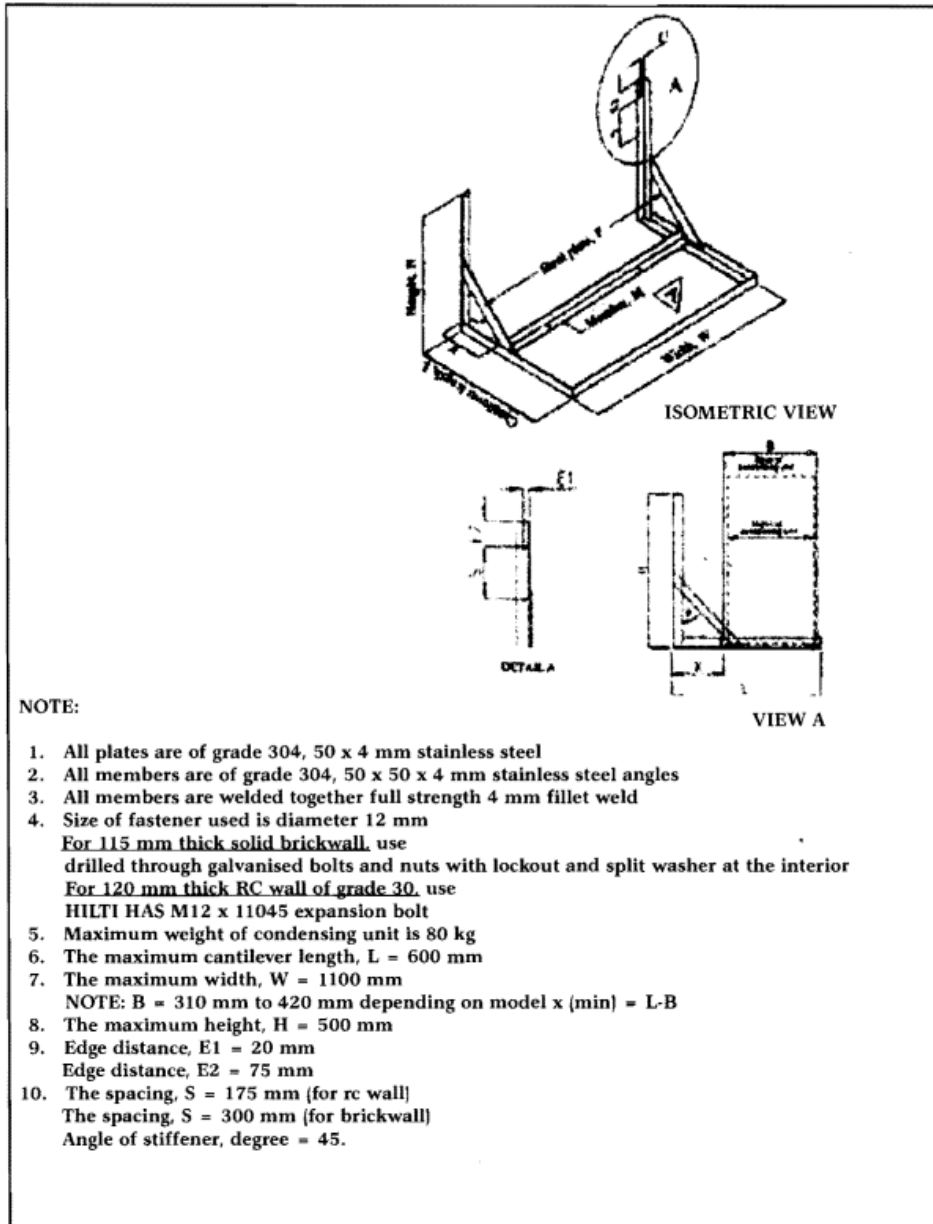

SCHEDULE 8

(regulation 28(1))

TASKS

PART 1

**DUTIES OF QUALIFIED PERSON APPOINTED UNDER SECTION 12(1)(a)
TO PREPARE PLANS OF GEOTECHNICAL ASPECTS OF UNDERGROUND
BUILDING WORKS**

1. In the preparation of plans relating to the geotechnical aspects of any excavation or other building works to construct a tunnel with a diameter, width or height of more than 2 metres, the qualified person shall —

(a) determine the site investigation, namely type, extent (which shall include quantity, layout and depth), method of sampling, coring and laboratory tests results for the design and construction of the tunnel;

(b) analyse the site investigation results and determine the geotechnical parameters for the design, taking into consideration onerous water conditions, seepage pressures, and surcharge, earth, water, construction and accidental loadings;

(c) determine and adopt appropriate method or model for the analysis and design including the consideration of drained, undrained and consolidation analyses, and appropriate drainage conditions;

(d) determine suitability of tunnelling method, sequence of construction, and tunnel support system including face pressures and ground support system;

(e) determine allowable limits of ground deformation and changes in groundwater and piezometric levels, and measures to control groundwater where required;

(f) analyse the stability of excavation and determine the ground stabilisation or improvement works as appropriate;

(g) design soil or rock reinforcement, where applicable, including the consideration of the structural and geotechnical capacity;

SCHEDULE 8 — (continued)

(h) determine the instrumentation and monitoring of geotechnical engineering parameters such as tunnel face pressures, pore pressures, water table level, ground deformation and stresses including the consideration of location, type and number of instruments, and frequency of monitoring and reporting; and

(i) assess monitoring results and site conditions to ensure that the geotechnical aspects during construction are within design assumptions and parameters at every critical stage of construction, and review or modify the design so as to ensure its adequacy as appropriate.

2. In the preparation of plans relating to the geotechnical aspects of any excavation or any building works for constructing, altering or repairing any earth retaining structure (including slope) in or for a caisson, cofferdam, trench, ditch, shaft or well for supporting earth which has a depth of more than 6 metres, the qualified person shall —

(a) determine the site investigation, namely type, extent (which shall include quantity, layout and depth), method of sampling, coring and laboratory tests results for the design and construction of the earth retaining structure including earth slope;

(b) analyse the site investigation results and determine the geotechnical parameters for the design of the earth retaining structure including consideration of onerous water conditions, seepage pressures, and surcharge, earth, water, construction and accidental loadings;

(c) determine and adopt appropriate method or model for the analysis and design including the consideration of drained, undrained and consolidation analyses, and appropriate drainage conditions;

(d) determine suitability of earth retaining structure types and scheme, and the method and sequence of construction;

(e) analyse the stability of the excavation work, taking into consideration groundwater, drainage and seepage conditions, basal heave, hydraulic up lift and piping, and determine the ground stabilisation or improvement works as appropriate;

(f) determine allowable limits of ground deformation and changes in groundwater and piezometric levels, and measures to control groundwater where required;

SCHEDULE 8 — (continued)

(g) design tie-backs, soil or rock reinforcement, where applicable, including the consideration of the structural and geotechnical capacity;

(h) ensure that drawings of the earth retaining structure, including earth slopes, are consistent with the calculations relating to the geotechnical aspects;

(i) determine the instrumentation and monitoring of geotechnical engineering parameters such as pore pressures, water table levels, ground deformation and stresses including the consideration of location, type and number of instruments, and frequency of monitoring and reporting; and

(j) assess monitoring results and site conditions to ensure that the geotechnical aspects during construction are within design assumptions and parameters at every critical stage of construction, and review or modify the design so as to ensure its adequacy as appropriate.

3. In the preparation of plans relating to the geotechnical aspects of such type of foundation works for buildings of thirty or more storeys, the qualified person shall —

(a) where a caisson, raft or piled-raft foundation is adopted —

- (i) determine the site investigation, namely type, extent (which shall include quantity, layout and depth), method of sampling, coring and laboratory tests results for the design and construction of the caisson, raft or piled-raft foundation;
- (ii) analyse the site investigation results and determine the geotechnical parameters, such as soil strength and deformation characteristics, pile shaft friction, downdrag, pile base resistance or bearing pressures and pile lateral geotechnical capacity, for the design of the foundation taking into consideration the onerous water conditions, seepage pressures, and loads from surcharge, earth, water and construction;
- (iii) determine and adopt appropriate method or model for the analysis and design including the consideration of drained, undrained and consolidation analyses, and appropriate drainage conditions;
- (iv) determine suitability of the foundation type and the method of construction;
- (v) where applicable, determine and analyse the negative shaft friction;

[Subsidiary]

SCHEDULE 8 — *(continued)*

- (vi) ensure that the drawings of the foundation are consistent with the calculations relating to the geotechnical aspects;
 - (vii) analyse the stability of excavation for the caisson or raft during construction taking into consideration groundwater, drainage and seepage conditions, basal heave, hydraulic up lift and piping, and determine the ground stabilisation or improvement works as appropriate;
 - (viii) analyse the forces and deformation of the lift or pile-raft foundation and stability of the foundation including the consideration of short-term and long-term conditions;
 - (ix) determine the number, location and types of load tests, analyse the results of load tests; or
- (b) where jacked-in piles or driven piles or bored cast in-place piles or barrettes are adopted —
- (i) determine the site investigation including the extent (which shall include the quantity, layout and depth), method of sampling, coring and laboratory tests results for the design and construction of the piled foundation;
 - (ii) analyse the site investigation results and determine the geotechnical parameters such as soil strength and deformation characteristics, negative skin friction or downdrag, pile shaft friction, founding depth, pile base resistance, pile group effects, settlement, bearing capacity, and where applicable, lateral geotechnical capacity; and
 - (iii) determine the load tests and analyse results of load tests to ensure that the pile shaft friction, founding depth, base resistance, pile movement, and other appropriate geotechnical parameters are within the design, and as appropriate, review or modify the design so as to ensure its adequacy.

SCHEDULE 8 — (continued)

PART 2

DUTIES OF SUPERVISING QUALIFIED PERSON FOR GEOTECHNICAL ASPECTS OF UNDERGROUND BUILDING WORKS

1. In the supervision of geotechnical aspects of any excavation or other building works to make a tunnel with a diameter, width or height of more than 2 metres, the supervising qualified person shall —

(a) supervise the implementation of instrumentation and monitoring of geotechnical parameters in accordance with the instrumentation and monitoring plan; and

(b) assess the ground conditions at the site and construction of the tunnel in relation to its impact on the geotechnical aspect of the design and review the performance and results of instrumentation and monitoring of the tunnelling works such that the geotechnical aspects are within the design at every critical stage.

2. In the supervision of geotechnical aspects of any excavation or any building works for constructing, altering or repairing any earth retaining structure including slope, in or for a caisson, trench, ditch, shaft or well with a depth or height of more than 6 metres, the supervising qualified person shall —

(a) supervise the implementation of instrumentation and monitoring of geotechnical engineering parameters in accordance with the instrumentation and monitoring plan;

(b) determine adequacy of the founding or penetration depth of embedded earth-retaining wall on site; and

(c) assess the ground conditions at the site and construction of the earth retaining structure (including earth slope) in relation to its impact on the geotechnical aspect of the design and review the performance and results of instrumentation and monitoring of the earth retaining structure including earth slope such that the geotechnical aspects are within the design at every critical stage.

[Subsidiary]

SCHEDULE 8 — *(continued)*

3. In the supervision of geotechnical aspects of such type of foundation works for buildings of thirty or more storeys, the supervising qualified person shall —

(a) where a caisson, raft or piled-raft foundation is adopted —

- (i) determine the founding or penetration depth of the caisson, raft or piles on site; and
- (ii) assess the ground conditions at the site and construction of the caisson, raft or piled-raft foundation in relation to its impact on the geotechnical aspect of the design, analyse the results of load tests, and review the performance and results of instrumentation and monitoring of the caisson, raft or piled-raft foundation to verify that the geotechnical aspects are within the design at every critical stage; or

(b) where jacked-in piles or driven piles or bored cast in-place piles or barrettes are adopted —

- (i) determine the founding or penetration depth of the piles on site; and
- (ii) assess the ground conditions at the site, analyse the results of load tests, and review the performance and results of instrumentation and monitoring of the piles to verify that the geotechnical aspects are within the design at every critical stage.